



14+



2



2,4m



1 = 2,4m
2 = 0,65m
3 = 2,51m

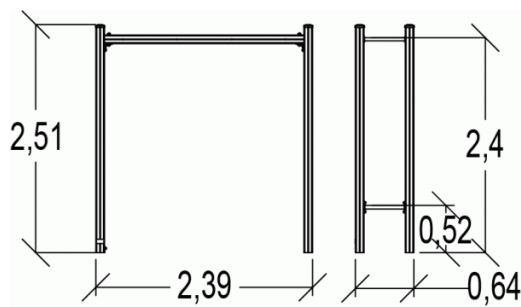

Spielwert :

3

Überqueren



x1

Hangeln



x1

Klimmzüge



x1



Montagehinweise

WICHTIG: Die Abmessungen der Sicherheitszone sind der Montageanleitung zu entnehmen und einzuhalten.

———— Fallraum (minimale normative Oberfläche)

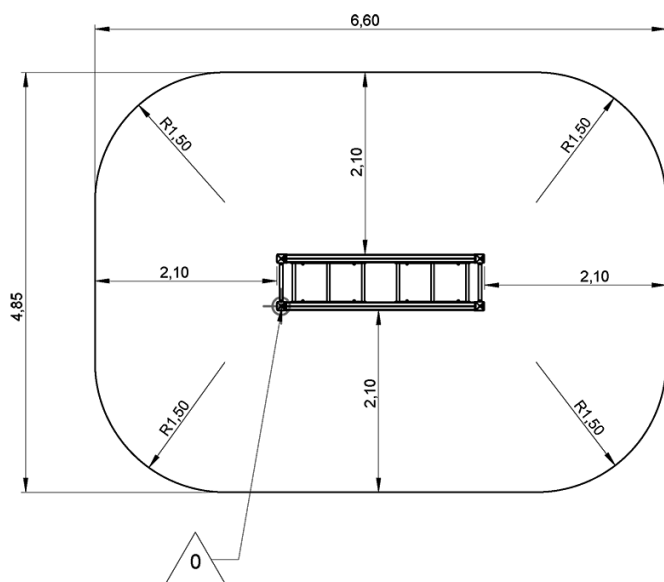
- - - - - Freiraum



		
1	2,4m	30m ²



2



01h45



0.1m³



18m²



133kg



20kg





Sportliche Aspekt

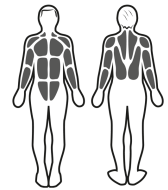

Muskelstimulation



Bewegungen

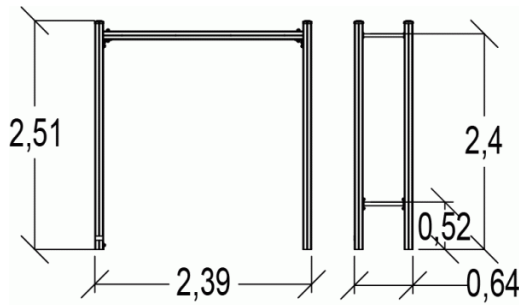

► **Sportliche Aktivitäten : 3**

Überqueren



Hangeln



Klimmzüge



Stärkung der Muskelkraft



Herz-Kreislauf-Training

Gleichgewicht



Koordination

► Montagehinweise

WICHTIG: Die Abmessungen der Sicherheitszone sind der Montageanleitung zu entnehmen und einzuhalten.

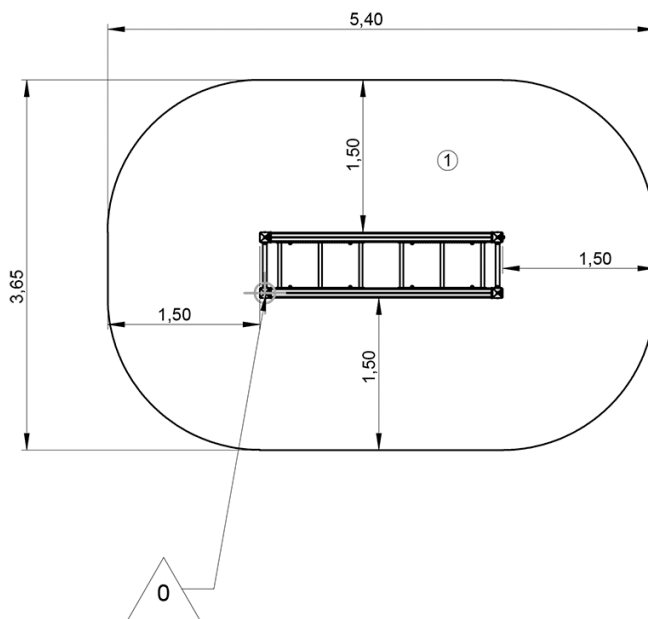
-  Fallraum (minimale normative Oberfläche)
-  Freiraum



		
1	1,4m	18m ²



2



01h45



0.1m³



18m²



133kg



20kg

