



6+



36



2,32m



1 = 5,63m
2 = 2,53m
3 = 3,01m



Motorische Einschränkung

Sensorische Einschränkung

Kognitive Einschränkung

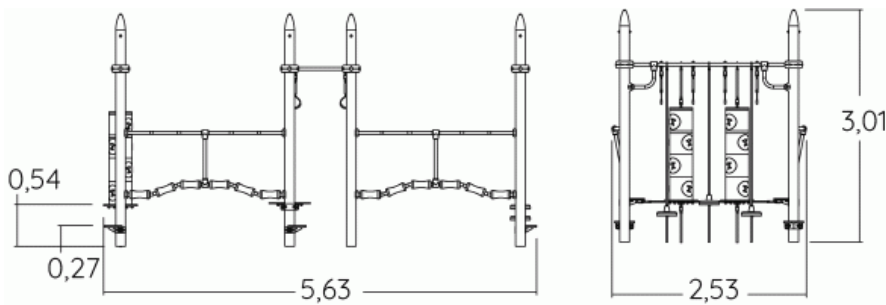
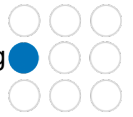

Spielwert :

19

Balancieren

Überqueren

Hangeln



x7



x9



x3

Elemente

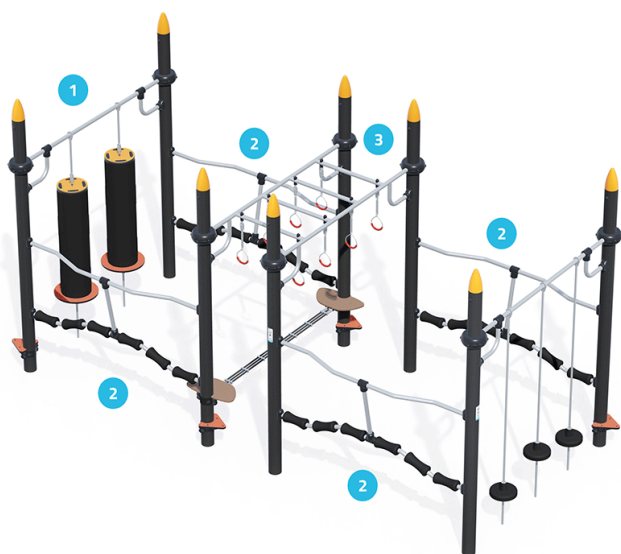

- ① Rouleaux suspendus
- ② Seitwärts-Brücke
- ③ Passerelle anneaux
- ④ Plôts suspendus

Montagehinweise

WICHTIG: Die Abmessungen der Sicherheitszone sind der Montageanleitung zu entnehmen und einzuhalten.

- Fallraum (minimale normative Oberfläche)
- Freiraum

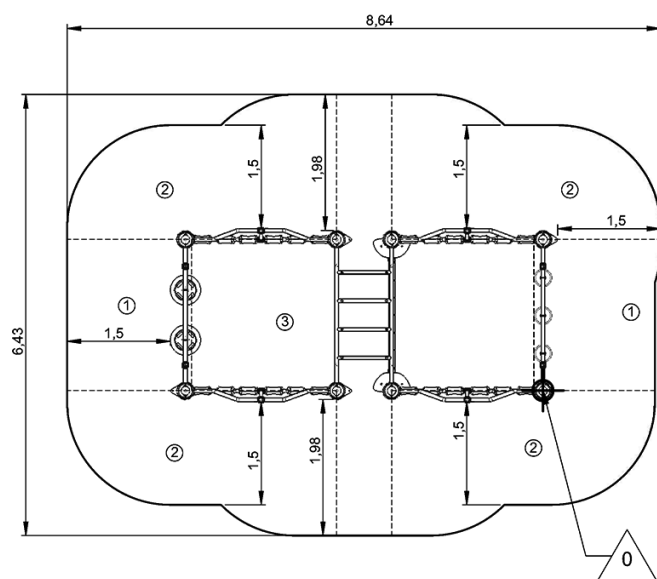

| | | |
|---|-------|--------------------|
| 1 | 0,6m | 8m ² |
| 2 | 0,86m | 27,5m ² |
| 3 | 2,32m | 14,5m ² |



2

09h00

0.65m³

50m²

625kg

107kg

EN

1176

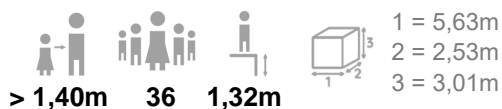

Sportliche Aspekt

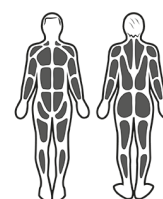

Muskelstimulation

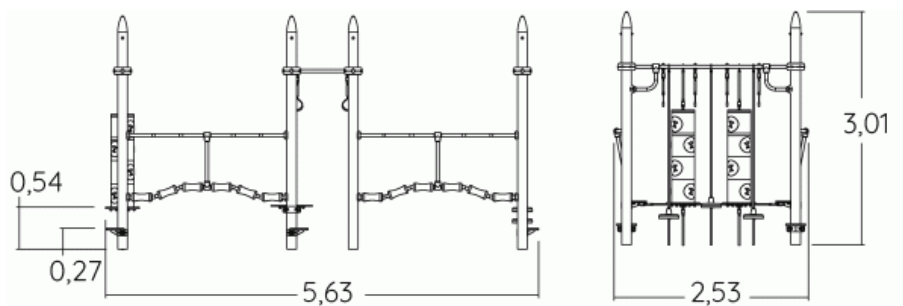

► Sportliche Aktivitäten : 19

Balancieren



Überqueren



Hangeln



Stärkung der Muskelkraft



Herz-Kreislauf-Training



Gleichgewicht



Koordination

Elemente

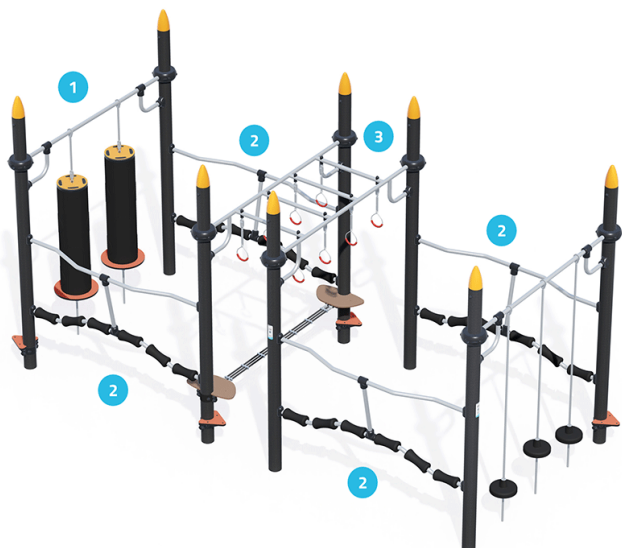

- ① Rouleaux suspendus
- ② Seitwärts-Brücke
- ③ Passerelle anneaux
- ④ Plôts suspendus

Montagehinweise

WICHTIG: Die Abmessungen der Sicherheitszone sind der Montageanleitung zu entnehmen und einzuhalten.

———— Fallraum (minimale normative Oberfläche)

- - - - - Freiraum

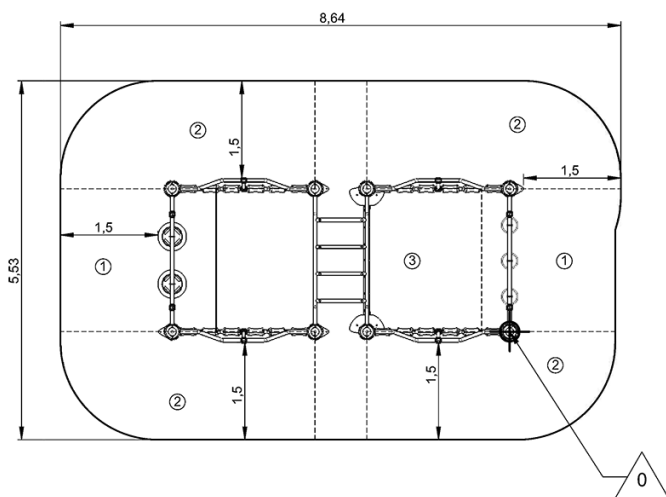

| | | |
|---|-------|--------------------|
| 1 | 0,6m | 10,5m ² |
| 2 | 0,86m | 25,5m ² |
| 3 | 1,32m | 12m ² |



2



09h00



0.65m³



50m²



625kg



107kg

