

Spielwert : 6

Balancieren

Überqueren

Hangeln



Montagehinweise

WICHTIG: Die Abmessungen der Sicherheitszone sind der Montageanleitung zu entnehmen und einzuhalten.

———— Fallraum (minimale normative Oberfläche)

- - - - - Freiraum

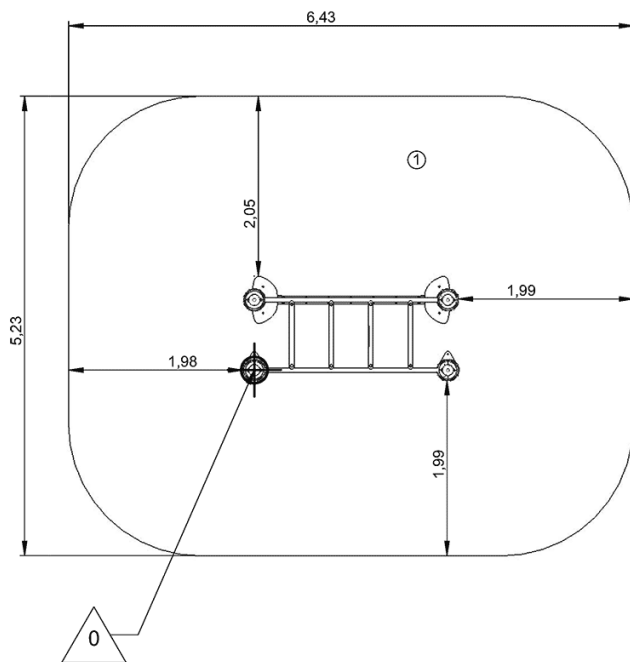

1	2,32m	32m ²



2



02h00



0.26m³



32m²



157kg



25kg

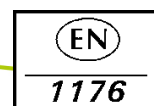

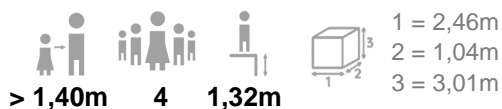

Sportliche Aspekt

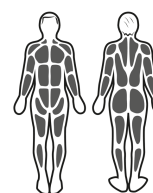

Muskelstimulation

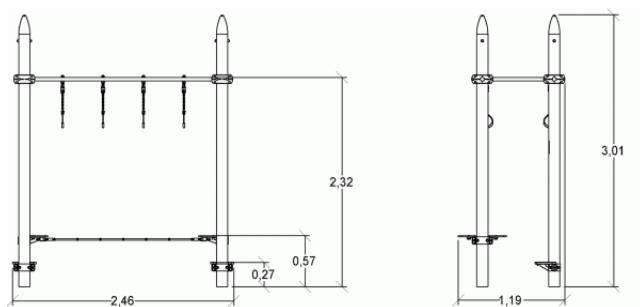

► Sportliche Aktivitäten : 6

Balancieren



x1

Überqueren



x3

Hangeln



x2

Stärkung der Muskelkraft



Herz-Kreislauf-Training





Gleichgewicht





Koordination

Montagehinweise

WICHTIG: Die Abmessungen der Sicherheitszone sind der Montageanleitung zu entnehmen und einzuhalten.

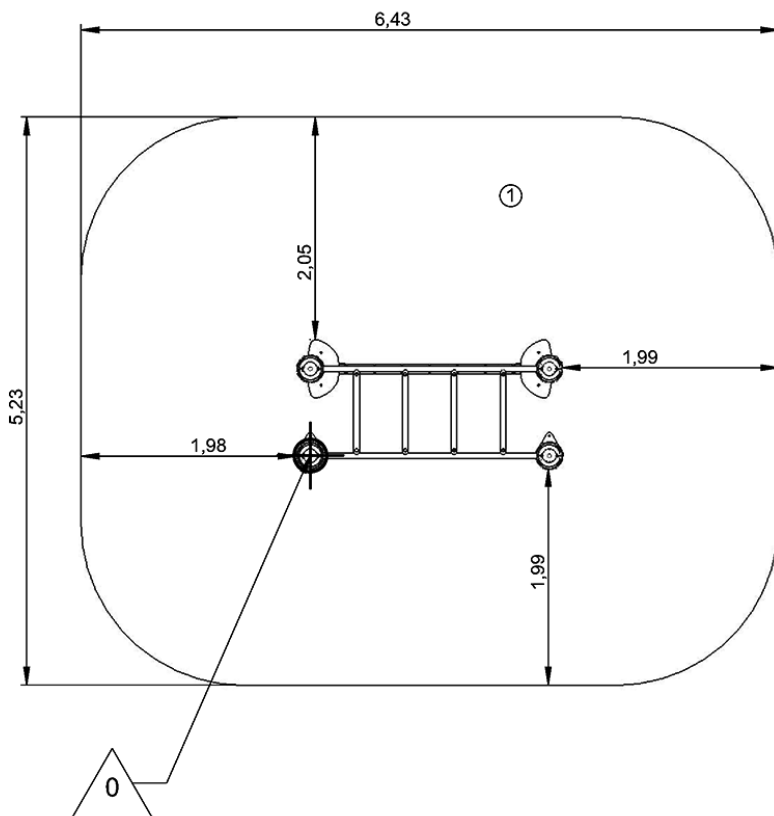
-  Fallraum (minimale normative Oberfläche)
-  Freiraum



		
1	1,32m	21m ²



2



02h00



0.26m³



32m²



157kg



25kg

